

CATALOGO PARTI DI RICAMBIO
SPARE PARTS LIST
CATALOGUE DES PIECES DE
RECHANGE
ERSATZTEILKATALOG
CATALOGO DE REPUESTOS



BED FORMER D45

FORIGO
roteritalia

ORDINAZIONE PARTI DI RICAMBIO

Specificare chiaramente:

- Modello e matricola della macchina (stampigliati sul telaio)
- Numero catalogo, numero di tavola, numero di riferimento, numero di codice, denominazione del particolare
- Quantità dei pezzi desiderati
- Mezzo di spedizione (se non specificato la ditta roteritalia si riserva di usare a sua discrezione il mezzo più opportuno) .

WHEN ORDERING SPARES

Clearly specify:

- The model and serial number of the machine (indicated on the machine frame)
- Catalog number, table number, reference number, code number, description of the item in question
- Number of spares required
- Dispatch means (if not specified, roteritalia reserves the right to use the most opportune means).

COMMANDE DE PIECES DE RECHANGE

Indiquer clairement:

- Modèle et matricule de la machine (Indiqués sur la machine)
- Numéro du catalogue, numéro du tableau, numéro de référence, numéro de code et dénomination de la pièce
- Quantité de pièces voulues
- Moyen d'expédition (s'il n'est pas spécifié, la maison roteritalia se réserve d'utiliser le moyen le plus opportun) ..

BESTELLEN VON ERSATZTEILEN

Klar und eindeutig angeben:

- Modell und Serien-Nr. der Maschine (der Maschine angeben)
- Katalog-Nr., Tafel-Nr., Sach-Nr., Schlüssel-Nr., Benennung des Einzelteils
- Anzahl der gewünschten Ersatzteile
- Versandmittel (Wenn keine Versandanweisung angegeben wird, behält sich Fa. roteritalia vor, das geeignetste Versandmittel nach eigenem Gutdunken auszuwählen).

PEDIDOS PARTES DE RECAMBIOS

Especificar claramente:

- Modelo y matricula de la maquina (estampillada sobre el chasis)
- Numero catalogo, numero de tabla, numero de referencia, numero de codigo, denominacion del particular
- Cantidad de las piezas deseada
- Medio de envio (sino especificado la empresa roteritalia se reserva de emplear a su discrecion el medio mas oportuno).

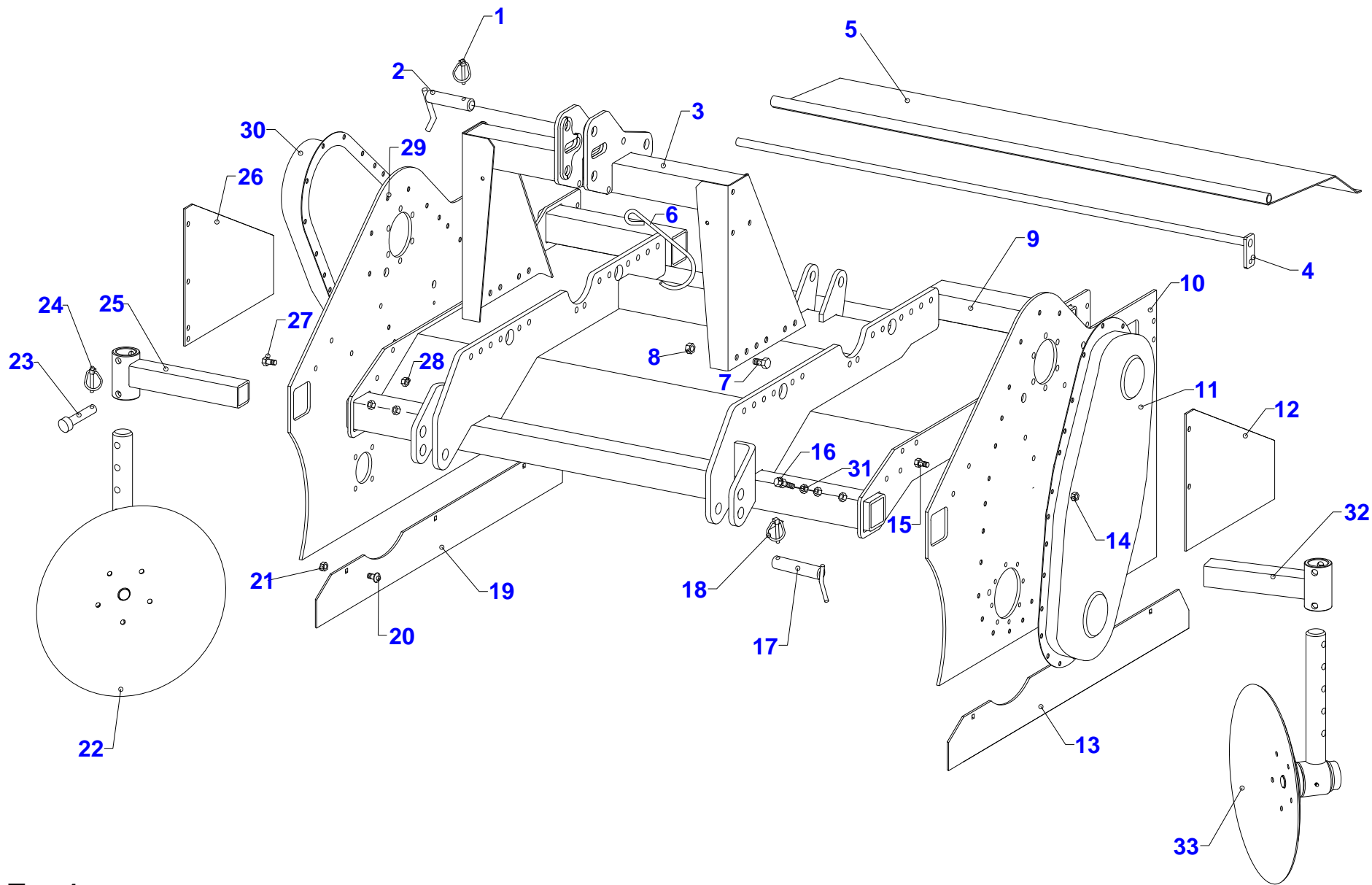

Tav.1

COD	REF	DESCRIZIONE	DESCRIPTION	DENOMINATION	BENENNUNG	DESCRIZION
SPC00511	1	SPINA A SCATTO D.9	PIN D. 9	GOUPILLE D. 9	BOLZEN D. 9	ESPINA D. 9
SPC00651	2	PERNO 28x145 ATTACCO TRATTORE	PIN 28x145	GOUJON 28x145	BOLZEN 28x145	PERNO 28x145
E1605302	3	PARTE SUPERIORE ATTACCO 3P F160-F200	LINKAGE 3P F160 - F200	ATTELAGE 3P F160 - F200	VODERE 3P F160 - F200	ENGANCHE 3P F160 - F200
D350030421	4	ASTA REGGICOFANO D35/D45-150	BAR FOR HOLDER BONNET D35/D45-150	BARRE PORTE CAPOT D35/D45-150	HALTER STANGE FUR HAUBE D35/D45-150	BARRA PORTA CAPO D35/D45-150
D350030422	4	ASTA REGGICOFANO D35/D45-170	BAR FOR HOLDER BONNET D35/D45-170	BARRE PORTE CAPOT D35/D45-170	HALTER STANGE FUR HAUBE D35/D45-170	BARRA PORTA CAPO D35/D45-170
D350030424	4	ASTA REGGICOFANO D35/D45-200	COMPLET CAPOT D35/D45-200	COMPLETE BONNET D35/D45-200	KOMPLET HAUBE D35/D45-200	COMPLETO CAPO D35/D45-200
D350030391	5	COFANO COMPLETO D35/D45-150	COMPLETE BONNET D35/D45-150	COMPLET CAPOT D35/D45-150	KOMPLET HAUBE D35/D45-150	CAPO COMPLETO D35/D45-150
D350030392	5	COFANO COMPLETO D35/D45-170	COMPLETE BONNET D35/D45-170	COMPLET CAPOT D35/D45-170	KOMPLET HAUBE D35/D45-170	COMPLETO CAPO D35/D45-170
D350030394	5	COFANO COMPLETO D35/D45-200	COMPLETE BONNET D35/D45-200	COMPLET CAPOT D35/D45-200	KOMPLET HAUBE D35/D45-200	CAPO COMPLETO D35/D45-200
E1002801	6	SOSTEGNO ALBERO CARDANICO ZINCATO	CARDAN SHAFT	SUPPORT CARDAN	HALTERUNG FUR GELENKWELLE	SOSTEN PARA CARDAN
VIT03621	7	VITE TE 8.8 14x45 UNI 5739	SCREW TE 8.8 14x45 UNI 5739	VIS TE 8.8 14x45 UNI 5739	SCHRAUBE TE 8.8 14x45 UNI 5739	TORNILLO TE 8.8 14x45 UNI 5739
DAG00301	8	DADO M 14 AUTOBLOCCANTE ALTO UNI 7473 DIN 982	NUT M 14 UNI 7473 DIN 982	ECROU M 14 UNI 7473 DIN 982	MUTTER M 14 UNI 7473 DIN 982	DADO M 14 UNI 7473 DIN 982
D450030140	9	TELAIO COMPLETO D45-150	COMPLETE FRAME D45-150	COMPLETE FRAME D45-150	KOMPLET RAHME D45-150	COMPLETO VIGA D45-150
D450030141	9	TELAIO COMPLETO D45-170	COMPLETE FRAME D45-170	COMPLET CHASSIS D45-170	KOMPLET RAHME D45-170	COMPLETO VIGA D45-170
D450030142	9	TELAIO COMPLETO D45-200	COMPLETE FRAME D45-200	COMPLET CHASSIS D45-200	KOMPLET RAHME D45-200	COMPLETO VIGA D45-200
D450010170	10	FIANCATA LATO ZAPPE D45 Sp.8	PANNEL SIDE ROTOR D45	BUTEE OTE' ROTOR D45	SEITLICHE ROTOR BLECHER D45	FLANCO LADO ROTOR D45
D350030150	11	CARTER LATO SMINUZZATORE E ROTORE A ZAPPE D35	CARTER SIDE ROTOR	CARTER COTE' ROTOR	CARTER SEITLICH ROTOR	CARTER LADO ROTOR
D350010610	12	BANDELLA POSTERIORE D35/D45 Sp.5	POSTERIOR PANNEL D35-D45	BARRE POSTERIEUR D35-D45	HINTERE BLECHER D35-D45	POSTERIOR BADELA D35-D45
D350010550	13	MINIGONNA D35/D45 Sp.6	INFERIOR PANNEL D35-D45	BARRE INFERIEUR BUTEE' D35-D45	UNTERE BLECHER D35-D45	BANDELA INFERIOR FIANCO D35-D45
DAG00101	14	DADO AUTOBL. 982 C.8 10x1,5 MA ZIN. B.	NUT 982 C.8 10x1,5 MA ZIN. B.	ECROU 982 C.8 10x1,5 MA ZIN. B.	MUTTER 982 C.8 10x1,5 MA ZIN. B.	DADO 982 C.8 10x1,5 MA ZIN. B.
VIT05901	15	VITE TE 8.8 M 10x25 NERA UNI 5739 DIN 933	SCREW TE 8.8 M10x25	VIA TE 8.8 M 10x25	SCHRAUBE TE 8.8 M 10x25	TORNILLO TE 8.8 M 10x25
VIT06201	16	VITE TE 8.8 16x70 UNI 5739 ZINCATA	SCREW TE M 16x70	VIS TE M 16x70	SCHRAUBE TE M 16x70	TORNILLO TE M 16x70
SPC00651	17	PERNO 28x145 ATTACCO TRATTORE	PIN 28x145	GOUJON 28x145	BOLZEN 28x145	PERNO 28x145
SPC00511	18	SPINA A SCATTO D.9	PIN D. 9	GOUPILLE D. 9	BOLZEN D. 9	ESPINA D. 9
D350010550	19	MINIGONNA D35/D45 Sp.6	INFERIOR PANNEL D35-D45	BARRE INFERIEUR BUTEE' D35-D45	UNTERE BLECHER D35-D45	BANDELA INFERIOR FIANCO D35-D45
VIT04411	20	VITE T.T.Q.S.T. 10x30 8.8 ZINCATA UNI 5732 DIN 603	SCREW TT 10X30 8.8	VIS TT 10X30 8.8	SCHRAUBE TT 10X30 8.8	TORNILLO 10X30 8.8
DAG00101	21	DADO AUTOBL. 982 C.8 10x1,5 MA ZIN. B.	NUT 982 C.8 10x1,5 MA ZIN. B.	ECROU 982 C.8 10x1,5 MA ZIN. B.	MUTTER 982 C.8 10x1,5 MA ZIN. B.	DADO 982 C.8 10x1,5 MA ZIN. B.
G3597002	22	SUPPORTO DISCO BOMBATO D. 460	SUPPORT D. 460 DX	SUPPORT D.460 DX	LAGERUNG D. 460 DX	SOPORTE D. 460 DX
G3598010	23	SPINOTTO FISSAGGIO DISCO G25-G35-G45	SPRING COTTER G325-G35-G45	GOUPILLE G325-G35-G45	BOLZEN G325-G35-G45	ESPINA G325-G35-G45
SPC00521	24	SPINA A SCATTO D. 6	SPRING D.6	GOUPILLE D.6	STIFT M..6	ESPINA D.6
G3662510	25	SUPPORTO PORTADISCO G35-G45	SUPPORT G35-G45	SUPPORT G35-G45	LAGERUNG G35-G45	SOPORTE G35-G45
D350010610	26	BANDELLA POSTERIORE D35/D45 Sp.5	POSTERIOR PANNEL D35-D45	BARRE POSTERIEUR D35-D45	HINTERE BLECHER D35-D45	POSTERIOR BADELA D35-D45
VIT00501	27	VITE TE M 12x30 UNI 5739 DIN 933	SCREW M 12x30	VIS M 12x30	SCHRAUBE M 12x30	TORNILLO TE M 12x30
DAG00201	28	DADO M 12x1,75 AUTOBLOCCANTE 982 C.8	NUT M 12x1,75 982 C.8	ECROU M 12x1,75 982 C.8	MUTTER M12x1,75 982 C.8	DADO M 12x1,75 982 C.8
D450010180	29	FIANCATA LATO SMINUZZATORE D45 Sp.8	PANNEL SIDE ROLLER D45	BUTEE COTE' ROULEAU D45	SEITLICHE WALZE BLECHER D45	FLANCO LADO RULO D45
D350030150	30	CARTER LATO SMINUZZATORE E ROTORE A ZAPPE D35	CARTER SIDE ROTOR	CARTER COTE' ROTOR	CARTER SEITLICH ROTOR	CARTER LADO ROTOR
DAG00421	31	DADO ESAGONALE MEDIO M16 UNI 5588 DIN934	NUT HEXAGONAL LOW M16 UNI 5588 DIN 934 ZN	ECROU HEXAGONAL BAS M16 UNI 5588 DIN 934	MUTTER SECHSECKING NIEDRIG M16	DADO HEXAGONAL BAJO M16
G3662510	32	SUPPORTO PORTADISCO G35-G45	SUPPORT G35-G45	SUPPORT G35-G45	LAGERUNG G35-G45	SOPORTE G35-G45
G3597012	33	SUPPORTO DISCO BOMBATO D. 460	SUPPORT D. 460 SX	SUPPORT D. 460 SX	LAGERUNG D. 460 SX	SOPORTE D. 460 SX

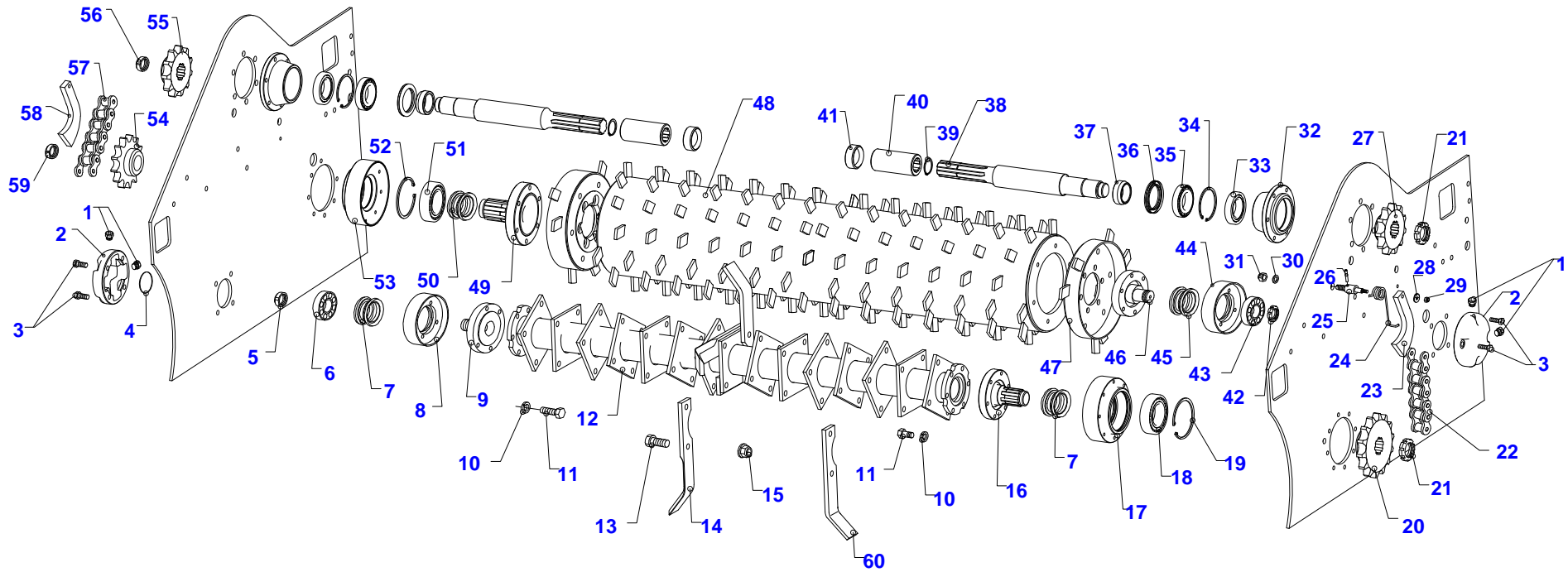

Tav.2

COD	REF	DESCRIZIONE	DESCRIPTION	DENOMINATION	BENENNUNG	DESCRIZION
TAP00401	1	TAPPO CON ESAGONO 3/8 GAS CIECO	HEXAGONAL CAP 3/8 G	BOUCHON HEXAGONAL 3/8 G	SECHSECKFORM PFROPFEN 3/8 G	TAPA CON HEXAGON 3/8 G
F4010010	2	COPPA ESTERNA LATO OPPOSTO F4	OPPOSITE SIDE SUMP F4	DISQUE ESTERIEURE COTE OPPOSE F4	GEGENUEBERLIEGENDE GUSSEISENFLANSCH F4	COPA ESTERNA LATO OPUESTO F4
VIT02621	3	VITE TE M 12x40x1,25 UNI 5740 NERA	SCREW TE M 12x40x1,25	VIS TE M 12x40x1,25	SCHRAUBE TE M 12x40x1,25	TORNILLO TE M 12x40x1,25
ANS06641	4	SPESSORE DI REGISTRAZIONE 80x100x2	ADJUSTER SHIM 80x100x2	CALE DE REGLAGE 80x100x2	STAERKE 80x100x2	ESPEJOR DE REGISTRO 80x100x2
DAG02701	5	GHIERA GUK 50x1,5	RING NUT GUK 50x1,5	FRETTE GUK 50x1,5	NUTMUTTER GUK 50x1,5	TUERCAS RODONDA INTAGLIATA GUK 50x1,5
CUS05501	6	CUSCINETTO 21309 Marca KOYO CC-45X100X25	BEARING 21309	ROULEMENT 21309	KUGELLAGER 21309	COJINETE 21309
GUA08101	7	TENUTA FRONTALE IN6460 PER F4/G45	DUAL FRONT SEAL IN6460 F4	ETANCHEITE FRONTALE IN6460 POUR F4	FRONTAL DICHTIGKEIT IN6460 F4	KIT TENUTA FRONTAL PARA ACEITE IN 6460 F4
F4009010	8	FLANGIA INFERIORE LATO OPPOSTO F4	LOWER FLANGE OPPOSITE SIDE F4	BRIDE INFERIEURE COTE OPPOSE F4	GEGENUEBERLIEGENDE UNTERE FLANSCH F4	BRIDA LADO OPUESTO F4
F4007010	9	ALBERO LATO OPPOSTO F4	OPPOSITE SIDE SHAFT F4	ARBRE COTE OPPOSE F4	GEGENUEBERLIEGENDE WELLE F4	ARBOL LADO OPUESTO F4
RON01511	10	GROWER PESANTE M14 NERA	GROWER WASHER M14	LOURDE GROWER M14	UNTERLEGSCHLEIBE M14	ARANDELA GROWER M14
VIT01021	11	VITE TE 10.9 M 14x40x1,5 ZINCATA UNI 5738 I	SCREW TE M 14x40x1,5	VIS TE M 14x40x1,5	SCHRAUBE TE M 14x40x1,5 VERZINKT	TORNILLO TE M 14x40x1,5
D450030010	12	ROTORE ANTERIORE D45-150	FRONT ROTOR D45-150	ROTOR ANTE'RIEUR D45-150	VOHNE ROTOR D45-150	ANTERIOR ROTOR D45-150
D450030020	12	ROTORE ANTERIORE D45-170	FRONT ROTOR D45-170	ROTOR ANTE'RIEUR D45-170	VOHNE ROTOR D45-170	ANTERIOR ROTOR D45-170
D450030030	12	ROTORE ANTERIORE D45-200	FRONT ROTOR D45-200	ROTOR ANTE'RIEUR D45-200	VOHNE ROTOR D45-200	ANTERIOR ROTOR D45-200
VIT01141	13	VITE TE M 14x1,5x50 FIL. 20 10.9 UNI 5738 Z	SCREW 14x1,5x50 FIL. 20 10.9 UNI 5738	VIS M 14x1,5x50 FIL. 20 10.9 UNI 5738	SCHRAUBE 14x1,5x50 FIL. 20 10.9 UNI 5738	TORNILLO 14x1,5x50 FIL. 20 10.9 UNI 5738
D450010360	14	DENTE 50x10 D45 Sx - STANDARD	TINE 50x10 SHORT MODEL	DENT 50x10 MODEL COURT	ZINKE 50x10 KURZE MODELL	DIENTE 50x10 MODEL CORTO
DAG02421	15	DADO M 14x1,5 ALTO CI. 10 DIN 6927 FLANGIATO S	NUT M 14x1,5 10.9	ECROU M 14x1,5 10.9	MUTTER M 14x1,5 10.9	DADO M 14x1,5 10.9
F4004010	16	ALBERO LATO TRASMISSIONE F4	SHAFT OF TRANSMISSION SIDE F4	ARBRE COTE TRANSMISSION F4	SEITENWAND ANTRIEBSWELLE F4	ARBOL LADO TRANSMISION F4
F4008010	17	FLANGIA INFERIORE LATO TRASMISSIONE F4	LOWER FLANGE TRANSMISSION SIDE F4	BRIDE INFERIEURE COTE TRANSMISSION F4	UNTERE ANTRIEBSFLANSCH F4	BRIDA LADO TRANSMISSION F4
CUS02701	18	CUSCINETTO 22212 marca KOYO	BEARING 22212	ROULEMENT 22212	KUGELLAGER 22212	COJINETES 22212
ANS01901	19	ANELLO SEEGER I 110	SEEGER RING I 110	ANNEAU SEEGER I 110	SEEGERRING I 110	ANILLO SEEGER I 110
F4016010	20	INGRANAGGIO INFERIORE Z14 11/2	LOWER GEAR Z14 11/2	ENGRENAGE INFERIEUR Z14 11/2	UNTERE ZAHNRAEDERE Z14 11/2	ENGRENAJE INFERIOR Z14 11/2
DAG02701	21	GHIERA GUK 50x1,5	RING NUT GUK 50x1,5	FRETTE GUK 50x1,5	NUTMUTTER GUK 50x1,5	TUERCAS RODONDA INTAGLIATA GUK 50x1,5
D45000010	22	CATENA R38SH 44 PASSI CHIUSA-RIBADITA	CHAIN R38SH 44P	CHAINE R38SH 44P	KETTE R38SH 44P	CADENA R38SH 44P
F4017010	23	PATTINO TENDICATENA F4	CHAIN STRETCHER SKID F4	PATIN-TENDEUR DE CHAINE F4	KETTENSANNER F4	TENSORCADENA F4
F4017210	24	MOLLA TENDICATENA	CHAIN STRETCHER SPRING	RESSORT TENDEUR DE CHAINE	KETTENSANNER FEDER	MUELLE PARA CADENA
F4017110	25	PERNO TENDICATENA F3-F35-F4	CHAIN STRETCHER PIN	GOUJON DU TENDEUR DE CHAINE F4	KETTENSANNER BOLZEN F4	PERNO PAR EXTENDER CADENA F4
SPC01101	26	SPINA ELASTICA 8x50	PIN 8X50	BROCHE 8x50	STIFT 8x50	ESPIÑA 8x50
F4013010	27	INGRANAGGIO SUPERIORE Z11 11/2	UPPER GEAR Z11 1 1/2	ENGRENAGE SUPERIEUR Z11 11/2	OBERE ZAHNRAEDER Z11 11/2	ENGRENAJE SUPERIOR Z11 11/2
RON02001	28	ROSETTA PIANA Di=11 De=30 ZINCATA	FLAT WASHER 10X40X2,5	RONDELLE PLAINE 10x40x2,5	ZAHNSCHLEIBE 10x40x2,5	ARANDELA PIANA 10X40X2,5
DAG00101	29	DADO AUTOBL. 982 C.8 10x1,5 MA ZIN. B.	NUT 982 C.8 10x1,5 MA ZIN. B.	ECROU 982 C.8 10x1,5 MA ZIN. B.	MUTTER 982 C.8 10x1,5 MA ZIN. B.	DADO 982 C.8 10x1,5 MA ZIN. B.
RON00601	30	ROSETTA PIANA Di=19 De=34 Sp.3 UNI 6592 DIN 125A ;	WASHER M 18	RONDELLE M 18	ZAHNSCHLEIBE M18	ARANDELLA M 18
DAG02851	31	DADO ESAGONALE M 18 AUTOBLOC. ALTO UNI 7473	NUT HEXAGONAL M 18 UNI 7473 DIN 982	ECROU HEXAGONAL M 18 UNI 7473 DIN 982	MUTTER SECHSECKING M 18 UNI 7473 DIN 982	DADO HEXAGONAL M 18 UNI 7473 DIN 982
G3501000	32	FLANGIA SUPERIORE TRASMISSIONE	FLANGE SUPERIOR TRANSMISSION	BRIDE SUPERIEUR TRSMISION	UNTENFLANSCH OBERE ANTRIEB	BRIDA SUPERIOR TRANSMISION
CUS06201	33	CUSCINETTO 30210 marca KOYO - 50X90X21.75	BEARING 30210	ROULEMENT 30210	KUGELLAGER 30210	COJINETE 30210
ANS00501	34	ANELLO SEEGER I 90 DIN472	SEEGER RING I 90	ANNEAU SEEGER I 90	SEEGERRING I 90	ANILLO SEEGER I 90
CUS06201	35	CUSCINETTO 30210 marca KOYO - 50X90X21.75	BEARING 30210	ROULEMENT 30210	KUGELLAGER 30210	COJINETE 30210
GUA07131	36	ANELLO DI TENUTA 65x90x10 BASL	OIL SEAL 65x85x10	PARE-HUILE 65x85x10	OLABDICHTUNG 65x85x10	ANILLO 65x90x10
G3511100	37	DISTANZIALE CUSCINETTI PER ALBERO ESAGONALE	BEARING SPACER	ENTRETOISE ROULEMENT	DISTANZSTUCK KUGEL LAGER	SEPARADOR COJINETE
D450010270	38	ALBERO TRASMISSIONE D45-150	SHAFT FOR D45-150	ARBRE POUR D45-150	WELLE FUR D45-150	ARBOL PAR D45-150
D450010280	38	ALBERO TRASMISSIONE D45-170	SHAFT FOR D45-170	ARBRE POUR D45-170	WELLE FUR D45-170	ARBOL OAR D45-170
D450010290	38	ALBERO TRASMISSIONE D45-200	SHAFT FOR D45-200	ARBRE POUR D45-200	WELLE FUR D45-200	ARBOL PAR D45-200
ANS01701	39	ANELLO SEEGER E 45	SEEGER RING E 45	ANNEAU SEEGER E 45	SEEGERRING E 45	ANILLO SEGER E 45
D350010221	40	BOCCOLA GIUNZIONE ALBERO RIDUTTORE D35	JOINT-BUSH FOR SHAFT	BOUCLE DE JOINT POUR ARBRE	VERLENGERUNGS-BUECHSE FUR WELLE	BUJE PARA ARBOL
D350010510	41	BOCCOLA DISTANZIALE ALBERO TRASMISSIONE D35	SHIM BUSH FOR SHAFT	BOUCLE CALE POUR ARBRE	DISTANZBUECHSE FUR WELLE	DISTANCIATOR BUJE PAR ARBOL
DAG01401	42	GHIERA GUK 40x1,5	RING NUT GUK 40x1,5	FRETTE GUK 40x1,5	NUTMUTTER GUK 40x1,5	TUERCAS RODONDA INTAGLIATA GUK 40x1,5
CUS06101	43	CUSCINETTO 21307 marca KOYO	BEARING 21307	ROULEMENT 21307	KUGEL LAGER 21307	COJINETE 21307
F3007020	44	FLANGIA INTERNA LATO OPPOSTO F3-F35	OPPOSITE INSIDE FLANGE F3-F35	BRIDE INTERIEUR COTE OPPOSE F3-F35	HINTERE GEGENUEBER FLANGE F3-F35	BRIDA INTERNA LADO OPUESTO F3-F35
GUA08001	45	TENUTA FRONTALE IN COPPIA FT0641/IN6360	DUAL FRONT SEAL FT0641 F3	ETANCHEITE FRONTALE FT0641 POUR F3	FRONTAL DICHTIGKEIT FT0641 F3	KIT TENUTA FRONTAL PARA ACEITE FT0641 F3
F3006020	46	ALBERO LATO OPPOSTO F3-F35-G35	OPPOSITE SIDE SHAFT F3	ARBRE COTE OPPOSE F3	GEGENUEBERLIEGENDE WELLE F3	ARBOL LADO OPUESTO F3
D350030530	47	PARTE LATERALE ROTORE POSTERIORE LATO OPP.	SEID ROTOR DISK	LATERAL DISQUE ROTOR	SEITLICHE ROTOR SCHLEIBE	DISCO ROTOR LATERAL
D350030570	48	ROTORE POSTERIORE-CENTRALE D35/D45-150	BAK ROTOR D35/D45-150	ROTOR POSTERIEUR D35/D45-150	HINTERE ROTOR D35/D45-150	POSTERIOR ROTOR D35/D45-150

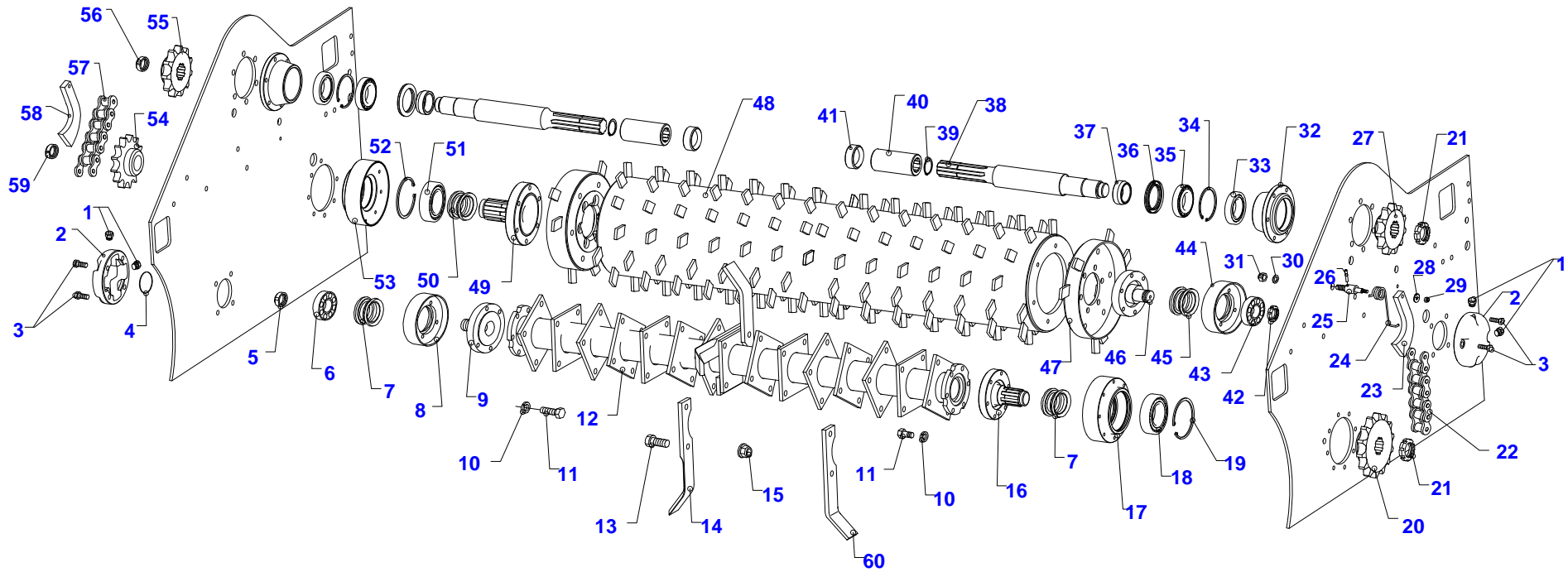

Tav.2

COD	REF	DESCRIZIONE	DESCRIPTION	DENOMINATION	BENENNUNG	DESCRIPCION
D350030590	48	ROTORE POSTERIORE-CENTRALE D35/D45-170	BAK ROTOR D35/D45-170	ROTOR POSTERIEUR D35/D45-170	HINTERE ROTOR D35/D45-170	POSTERIOR ROTOR D35/D45-170
D450030410	48	ROTORE POSTERIORE-CENTRALE D35/D45-200	BAK ROTOR D35/D45-200	ROTOR POSTERIEUR D35/D45-200	HINTERE ROTOR D35/D45-200	POSTERIOR ROTOR D35/D45-200
F3002020	49	ALBERO LATO TRASMISSIONE F3-F35-G35	SHAFT OF TRANSM. F3	ARBRE COTE TRANSMISSION F3	SEITLICHE ANTRIEBSWELLE F3	ARBOL LADO TRANSMISION F3
GUA08001	50	TENUTA FRONTALE IN COPPIA	DUAL FRONT SEAL FT0641 F3	ETANCHEITE FRONTALE FT0641 POUR F3	FRONTAL DICHTIGKEIT FT0641 F3	KIT TENUTA FRONTAL PARA ACEITE FT0641 F3
CUS03501	51	CUSCINETTO 21310 marca KOYO	BEARING 21310	ROULEMENT 21310	KUGELLAGER 21310	COJNETE 21310
ANS01901	52	ANELLO SEEGER I 110	SEEGER RING I 110	ANNEAU SEEGER I 110	SEEGERRING I 110	ANILLO SEEGER I 110
F3004020	53	FLANGIA INFERIORE LATO TRASMISSIONE F3-F35-G35	LOWER FLANGE TRANSM. SIDE F3-F35-G35	BRIDE INFERIEURE COTE TRANSMISSION F3-F35-G35	UNTERE ANTRIEBSFLANSCH F3-F35-G35	BRIDA LADO TRANSMISSION F3-F35-G35
F3016010	54	INGRANAGGIO INFERIORE ASA 100 Z=13	LOWER GEAR ASA 100 Z=13	ENGRENAGE INF. ASA 100 Z=13	UNTERE ZAHNRAEDER ASA 100 Z=13	ENGRANAJE INFERIOR ASA 100 Z=13
D450020010	55	PIGNONE SUPERIORE Z.12 LATO SMINUZZATORE D4!	SUPERIOR GEAR-CHAIN D45	ENGRANAGE SUPERIOR CHAINE D45	OBERE RAEDER KETTE D45	SUPERIOR ENGRANAJE CADENA D45
DAG01601	56	GHIERA GUK 45x1,5	RING NUT GUK 45x1,5	FRETTE GUK 45x1,5	NUTMUTTER GUK 45x1,5	TUERCAS RODONDA INTAGLIATA GUK 45x1,5
D3500010	57	CATENA ASA 100 HE 50 PASSI CHIUSA-RIBADITA D35/D4!	CHAIN ASA 100 HE	CHAINE ASA 100 HE	KETTE ASA 100 HE	CADENA ASA 100 HE
F3031020	58	SLITTA TENDICATENA F3	CHAIN STRETCHER SKID F3	TRINEAU TENDEUR DE CHAINE	KETTENSANNER F3	TENSORCADENA F3
DAG01601	59	GHIERA GUK 45x1,5	RING NUT GUK 45x1,5	FRETTE GUK 45x1,5	NUTMUTTER GUK 45x1,5	TUERCAS RODONDA INTAGLIATA GUK 45x1,5
D450010350	60	DENTE 50x10 D45 Dx - STANDARD	TINE 50x10 SHORT MODEL	DENT 50x10 MODEL COURT	ZINKE 50x10 KURZE MODELL	DIENTE 50x10 MODEL CORTO

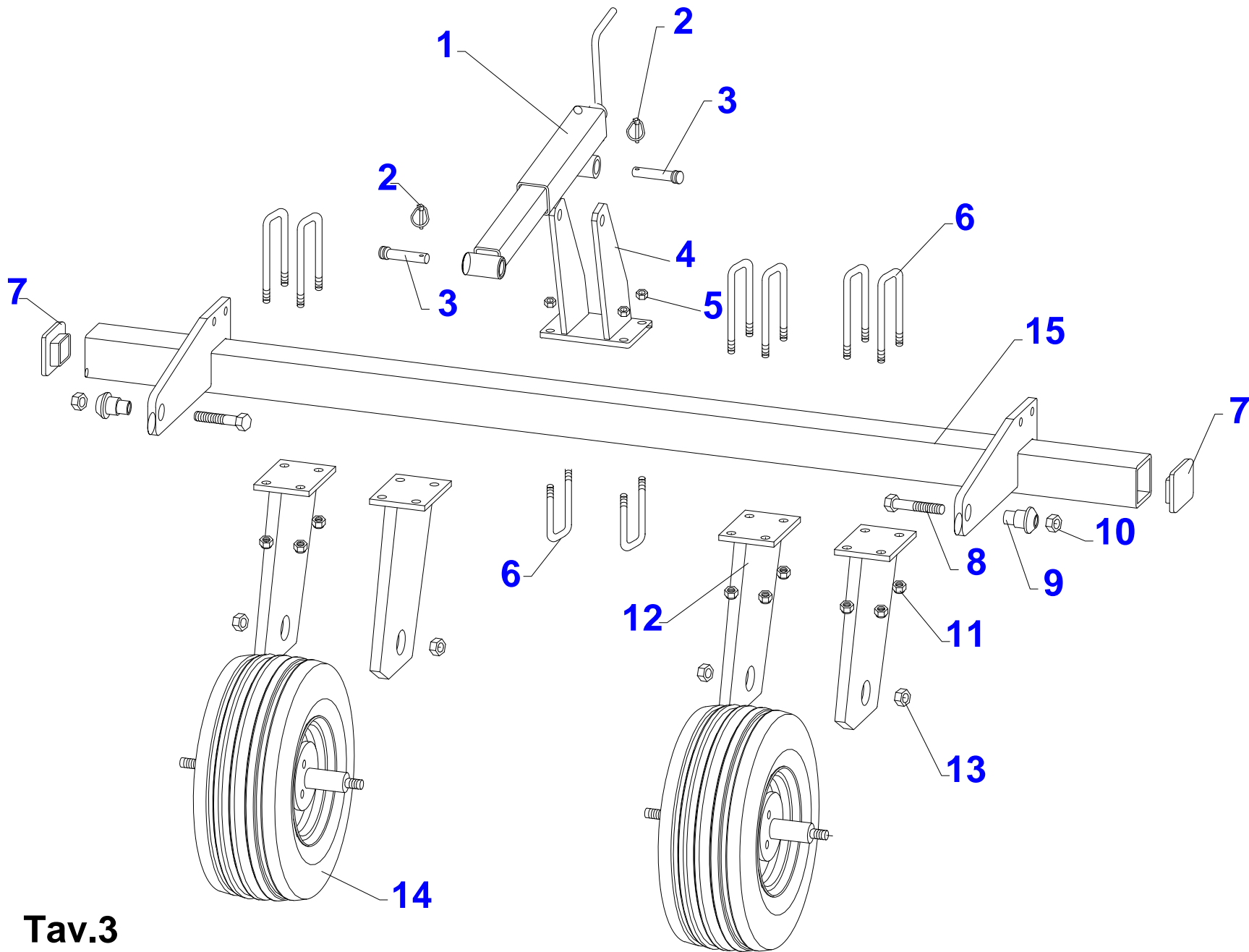

Tav.3

COD	REF	DESCRIZIONE	DESCRIPTION	DENOMINATION	BENENNUNG	DESCRIPCION
D350030480	1	MANOVELLA DI REGOLAZIONE RUOTE POSTERIORE	CRANK REG. WHEELS	MANIVELLE REG. ROUTE	SPINDEL REG. RAEDER	MANIVELE REG. RUEDA
SPC00511	2	SPINA A SCATTO D.9	PIN D. 9	GOUPILLE D. 9	BOLZEN D. 9	ESPIÑA D. 9
SPC01701	3	SPINA TERZO PUNTO 3a CATEGORIA D.19	PIN FOR 3-POINT 3° CAT.	GOUJON HAUT 3° CAT.	SPLINT III KAT.	ESPIÑA PARA ENGANCHE 3° CAT.
D350030300	4	GRUPPO DI ATTACCO MANOVELLA D35	SUPPORT CRANK D35	SUPPORT MANIVELLE D35	SPINDEL-HALTERUNG D35	SOPORTE MANIVELA D35
DAG00301	5	DADO M 14 AUTOBLOCCANTE ALTO UNI 7473 DIN 982	NUT M 14 UNI 7473 DIN 982	ECROU M 14 UNI 7473 DIN 982	MUTTER M 14 UNI 7473 DIN 982	DADO M 14 UNI 7473 DIN 982
VIT04341	6	CAVALLOTTO QUADRO 80x80 M14 ZINCATO	SQUARE SCREW 80x80 M14	VIS CARRE' 80x80 M14	QUADRATISCH BUGELBOLZEN 80x80 M14	ATAQUE 80x80 M14
TAP08111	7	TAPPO CHIUS. TUBOLARE 80x80 PLASTICA NERO	STOPPER	BONDE	DECKEL	TAPA
VIT06211	8	VITE TE 8.8 UNI5737 16x70 ZINCATA	SCREW TE M 16x70 ZINC. B	VIS TE M 16x70 ZINC. B.	SCHRAUBE TE M 16x70 ZINC. B.	TORNILLO TE M 16x70 ZINC. B.
D350010141	9	BOCCOLA SUPPORTO BRACCI PORTA RUOTA	BUSH	BOUCLE	BUECHSE	BUJE
DAG00401	10	DADO AUTOBL. 982 C.8 16x2 MA ZIN. B.	NUT 982 C.8 16x2 MA ZIN. B.	ECROU 982 C.8 16x2 MA ZIN. B.	SELBSTSTOPP MUTTER 982 C.8 16x2 MA ZIN. B.	DADO 982 C.8 16x2 MA ZIN. B.
DAG00301	11	DADO M 14 AUTOBLOCCANTE ALTO UNI 7473 DIN 982	NUT M 14 UNI 7473 DIN 982	ECROU M 14 UNI 7473 DIN 982	MUTTER M 14 UNI 7473 DIN 982	DADO M 14 UNI 7473 DIN 982
D450030310	12	SUPPORTO RUOTA POSTERIORE D45 SALDATO	SUPPORT WHEELS	SUPPORT ROUES	TRAEGER RAEDER	SOPORTE RUEDA
DAG00601	13	DADO DIN 982 M 20x1,5 AUTOBLOCCANTE ALTO	NUT 20 MB	ECROU 20 MB	MUTTER 20 MB	DADO 20 MB
D450030540	14	RUOTA COMPLETA PER BRACCIO DOPPIO D45	WHEEL D45	ROUE D45	RAEDER D45	RUEDA D45
D450030200	15	REGOLAZIONE POSTERIORE D45-150 SALDATA	SUPPORT BAR WHEELS D45-150	BARRE SUPPORT ROUES D45-150	TRAEGERSTANGE FUR RAEDER D45-150	BARRA SOPORTE RUEDA D45-150
D450030210	15	REGOLAZIONE POSTERIORE D45-170 SALDATA	SUPPORT BAR WHEELS D45-170	BARRE SUPPORT ROUES D45-170	TRAEGERSTANGE FUR RAEDER D45-170	BARRA SOPORTE RUEDA D45-170
D450030220	15	REGOLAZIONE POSTERIORE D45-200 SALDATA	SUPPORT BAR WHEELS D45-200	BARRE SUPPORT ROUES D45-200	TRAEGERSTANGE FUR RAEDER D45-200	BARRA SOPORTE RUEDA D45-200

Tav.4

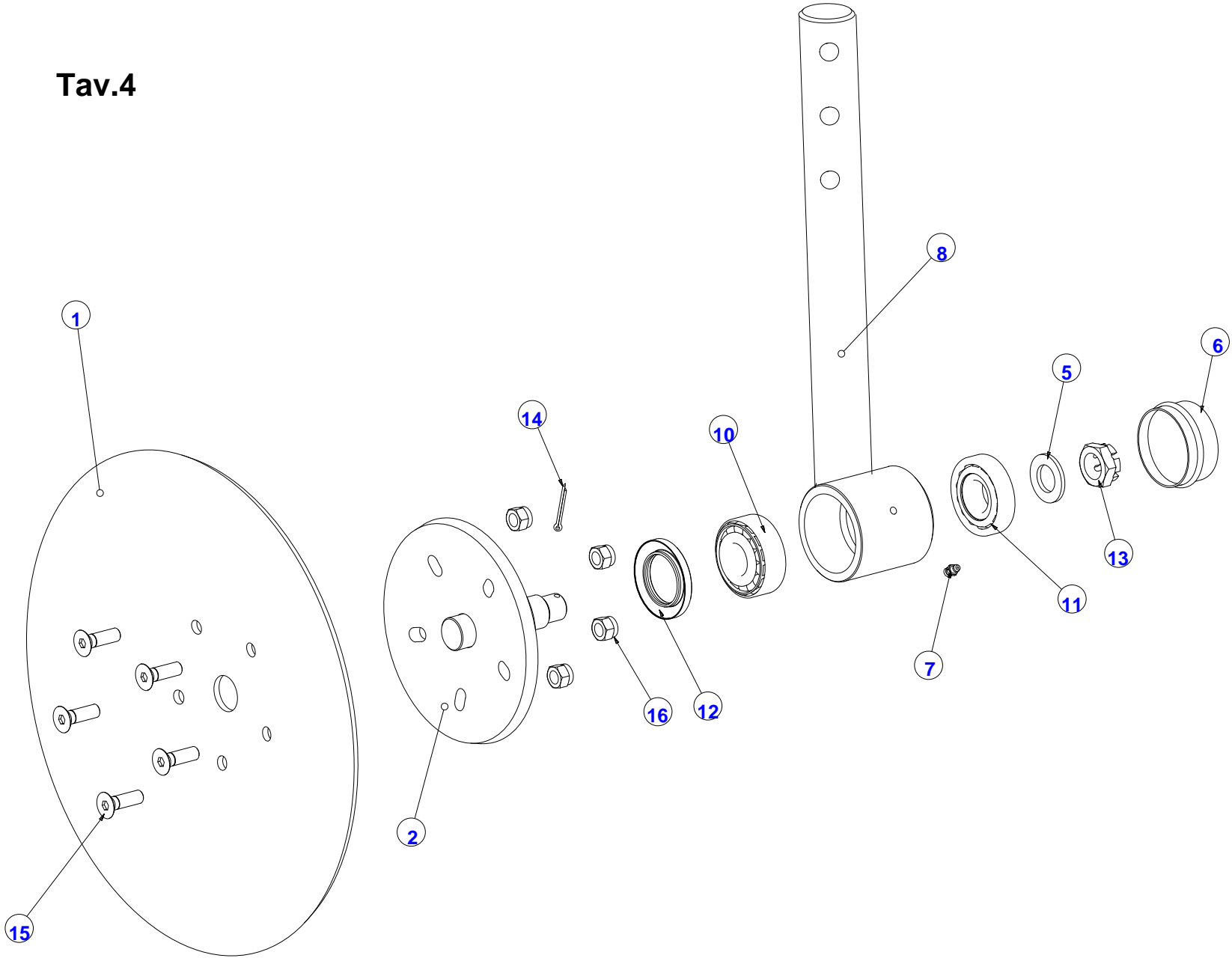

COD	REF	DESCRIZIONE	DESCRIPTION	DENOMINATION	BENENNUNG	DESCRIZION
DF000501	1	DISCO FRANGIZOLLE D. 460	DISCH 0 500 COMPLETE	DISQUE 0 500 COMPLET	METALLSCHEIBE 500 KPL.	DISCO 0 500 COMPLETO
G350030340	2	PERNO SALDATO SU FLANGIA G35/G45	FLANGE WITH PIN	BRIDE AVEC GOUJON SAUDER	FLANSCH MIT BOLZEN	BRIDA CON PERNO
RON00401	5	ROSETTA PIANA M24 ZINCATA DIN 125/A UNI 6592	WASHER M24	RONDELLE M 24	UNTERLEGSCHIEBE M24	ARANDELA M24
CAT01001	6	CAPPELOTTO D.72 CHIUSURA DISCHI G35/G45	CLOSED CAP	BOUCHON DE CLOTURE	GESCHLOSSENE KNOPF	TAPA DE CLAUSURA
VLD00201	7	INGRASSATORE DIRITTO 8X1,25 MA AMA 278/A	GREASE NIPPLE 8x1,25 MA	GRAISSEUR DROIT 8x1,25 MA	SCHMIERNIPPEL 8x1,25 MA	ENGRASADOR 8x1,25 MA
G350030320	8	MOZZO Dx G35 SALDATO	SUPPORT DISK RT. G35	SUPPORT DISQUE ADROIT G35	HALTERUNG FUER SCHEIBE RT. G35	SOORTE PARA DISCO DERECHA G35
G350030330	8	MOZZO Sx G35 SALDATO	SUPPORTFOR DISK LT. G35	SUPPORTE POUR DISQUE GAUCHE G35	HALTERUNG FUER SCHEIBE LK G35	SOORTE PARA DISCO IZQUIERDA G35
CUS01561	10	CUSCINETTO 32306 MARCA ARB	BEARING 32306	ROULEMENT 32306	KUGELLAGER 32306	COJINETE 32306
CUS01571	11	CUSCINETTO 30306 MARCA ARB	BEARING 30306	ROULEMENT 30306	KUGELLAGER 30306	COJINETE 30306
GUA05941	12	ANELLO DI TENUTA 45x72x8 BA	RING SEAL 45x72x8 BA	RING SEAL 45x72x8 BA	Ring-Dichtung 45x72x8 BA	ANILLO DE SELLO 45x72x8 BA
DAG00750	13	DADO A CORONA M 24x2 DIN 5594	CROWN NUT M 24x2	ECROU COURONNE M 24x2	MUTTER KRANZ M 24x2	DADO A CORONA M 24x2
SPC02361	14	COPIGLIA B 4x40 UNI 1336	ELASTIC PIN 4x40	BROCHE ELASTIQUE 4x40	SPANNSTIFT 4x40	ESPINA 4x40
VIT02501	15	VITE TSPEI 10.9 M 12x40 UNI5933 NERA	SCREW M 12X40	VIS TETE FRAISEE M 12x40 10.9	SCHRAUBE M 12x40 SENKKOPF	TORNILLO M 12X40
DAG00201	16	DADO M 12x1,75 AUTOBLOCCANTE 982 C.8	NUT M 12x1,75 982 C.8	ECROU M 12x1,75 982 C.8	MUTTER M12x1,75 982 C.8	DADO M 12x1,75 982 C.8



46035 Ostiglia Mantova ITALY
Via Brennero Nord, 9 - Zona Industriale
Tel. +39 0386 32691
Fax. +39 0386 31250
www.forigo.it

La presente Ditta si riserva il diritto di modificare, a propria discrezione, i dati contenuti nel libretto qualora lo ritenesse necessario per un miglioramento tecnico o commerciale del prodotto.

The Company reserves the right to modify the data in this manual whenever this is considered necessary for technical or commercial improvements regarding the products itself.

Toujours Soucieux d'améliorer ses productions, Roteritalia se réserve le droit de modifier sans préavis les caractéristiques et les données des matériels présentés dans ce document.

Die herstellerfirma behält sich vor, die in diesem Heft enthaltenen Angaben jederzeit nach eigenem Ermessen abzuändern, wenn das aufgrund technischer oder vertriebsbedingter Verbesserungen erforderlich wird.

La firma Roteritalia se reserva el derecho de modificar sin previo aviso las características de los equipos presentados en esta publicación.